

## 9.12 BONES AND JOINTS

Bones can last for centuries and in some cases for millions of years. They provide the anthropologist with a means of tracing both the cultural and the physical development of man. Because of the importance of bone to proper functioning of the body, a number of medical specialists such as the dentist, orthopedic surgeon and radiologist are concerned with the health of bone. Bones are also of interest to medical physicists and engineers because they deal with engineering problems concerning static and dynamic loading forces that occur during standing, walking, running, lifting and so forth. Nature has solved these problems extremely well by varying the shapes of the various bones in the skeleton and the type of bone tissue of which they are made. Bone has six important functions in the body: support, locomotion, protection of various organs, storage of chemicals, nourishment, and sound transmission (e.g. the middle ear). Bone consists of two different types of materials plus water. They are collagen, the major organic fraction, which is about 40% of the weight of solid bone and 60% of its volume and bone mineral, the so called inorganic component of the bone, which is about 60% of the weight of the bone and 40% of its volume. Either of the components may be removed from the bone, and in each case the remainder, composed of only collagen or bone mineral, looks like the original bone. The collagen remainder is quite flexible, like a chunk of rubber, and can even be bent into a loop. When collagen is removed from the bone, the bone mineral remainder is very fragile and can be crushed with the fingers. Collagen is produced by the osteoblastic cells and mineral is then formed on the collagen to produce bone (Cameron, 1978).

### 9.12.1 Bone mineral density

The strength of the bone depends to a large extent on the mass of bone mineral present. In diseases like osteoporosis the bone mineral mass is considerably reduced. Up to a few years ago osteoporosis was difficult to detect until a patient appeared with a broken hip or a crushed vertebra. By that time it was too late to use preventive therapy. Thus bone mineral is very important and commonly measured to detect bone diseases such as osteoporosis. The bone mineral content of specimens can be measured by ashing the specimen in a furnace or demineralizing it in a decalcifying solution (Ashman, 1989). The most commonly used technique for noninvasively measuring bone mineral content in the bone is dichromatic or dual photon absorptiometry (DPA).

In the early part of the 20th century, X rays were used to measure the amount of bone mineral present in the bone. But there are some major problems with using an ordinary X ray: the usual X-ray beam has many different bands of energy, and the absorption of X rays by calcium varies rapidly with energy in this range of energies; the relatively large beam contains much scattered radiation when it reaches the film; the film is a poor tool for making quantitative measurements since it is nonlinear with respect to both the amount and the energy of X rays. The net result of these problems is that a large change in the bone mineral mass (30 to 50%) must occur between the taking of two X rays of the same patient before a radiologist can be sure that there has been a change. Figure 9.10 shows that in dual photon absorptiometry, three problems with the X-ray technique are largely eliminated by using an X-ray source filtered to yield two

monoenergetic X-ray beams at about 30 keV and 70 keV, a narrow beam to minimize scatter, and a scintillation detector that detects all photons and permits them to be sorted by energy and counted individually. Tests are frequently made in the spine, hip, and forearm but can be done on the entire body.

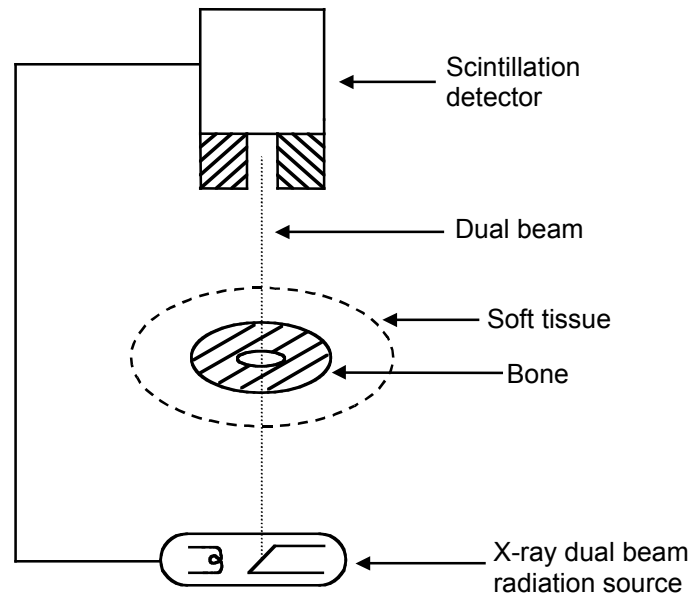

**Figure 9.10** In a dual photon absorptiometer, an X-ray source is filtered to emit at two discrete energies.

Hologic (2000) improves clinical bone densitometry by integrating bone mineral density (BMD) with Instant Vertebral Assessment (IVA). IVA, possible only with fan-beam technology, generates a high-resolution image of the entire lateral spine in just 10 s, enabling physicians to visually assess vertebral status for a more accurate determination of fracture risk than just BMD alone. A different instrument measures the speed of sound (SOS, in m/s) and broadband ultrasonic attenuation (BUA, in dB/MHz) of an ultrasound beam passed through the heel, and combines these results to obtain the Quantitative Ultrasound Index (QUI). The output is also expressed as a T-score and as an estimate of the Bone Mineral Density (BMD, in  $\text{g}/\text{cm}^2$ ) of the heel.

### 9.12.2 Stress and strain

#### *Tensile loads*

When forces are applied to any solid object, the object is deformed from its original dimensions. At the same time, internal forces are produced within the object. The relative deformations created at any point are referred to as strains at that point. The internal force intensities (force/area) are referred to as stresses at that point. When bone is subjected to forces, these stresses and strains are introduced throughout the structure and can vary in a very complex manner (Ashman, 1991).

Figure 9.11(a) shows a cylindrical bar of length  $L$  and a constant cross-sectional area  $A$  subject to a pure tensile force  $F$ . As the load is applied, the cylinder begins to stretch. This situation can be described by an equation that describes the stretching of a spring (Hooke's law):

$$F = kx \tag{9.22}$$

where  $F$  is the applied force,  $x$  is the change in length or elongation of the spring, and  $k$  is the spring constant or stiffness of the spring.

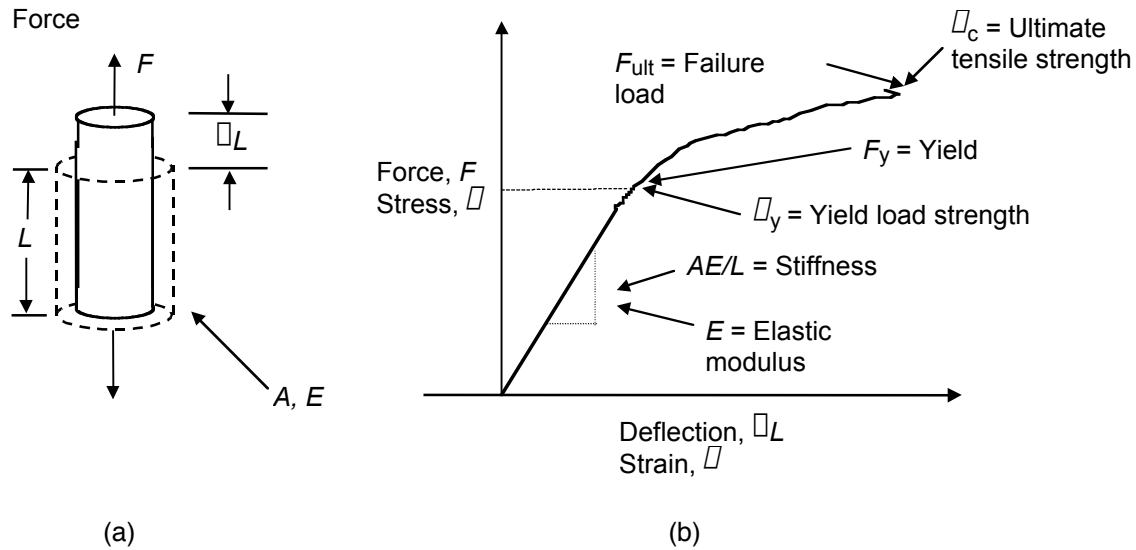

Figure 9.11 Tensile stress  $\sigma$  on a cylindrical bar causes tensile strain  $\epsilon$

The analogous relation for stretching of the cylinder is

$$\Delta L = \frac{FL}{AE} \tag{9.23}$$

where  $\Delta L$  is the elongation of the cylinder,  $L$  is the original unstretched length,  $A$  is the cross-sectional area,  $F$  is the force and  $E$  is the elastic (Young's) modulus (18 GPa for compact bone).

Tensile, or uniaxial, strain,  $\epsilon$  can be calculated using the formula

$$\epsilon = \frac{\Delta L}{L} \tag{9.24}$$

Similarly, tensile stress,  $\sigma$ , is calculated using the formula

$$\sigma = \frac{F}{A} \tag{9.25}$$

These tests can be performed on specimens with different lengths, cross-sectional areas and under forces of varying magnitudes (Black, 1988).

Figure 9.11(b) shows that a cylinder of bone tested in tension yields a linear region (also known as the elastic region) where the atoms of the bone are displaced only slightly by reversible stretching of the interatomic bonds. This is followed by a nonlinear region where yielding and internal damage occurs, often involving irreversible rearrangement of the structure. After yielding, nonelastic deformation occurs until finally failure or fracture results. The load at which yielding occurs is referred to as the yield load,  $F_y$ . The load at which failure occurs is called the ultimate or failure load,  $F_{ult}$ . This curve describes the behavior of the structure since the curve differs for a different cross-sectional area or different length. It also represents the mechanical behavior of the material as opposed to the behavior of the structure. In the stress–strain curve, the material yields at a stress level known as the yield strength and fractures at a stress level known as the fracture strength or the ultimate tensile strength. Toughness is the ability to absorb energy before failure and is calculated from the total area under the stress–strain curve, expressed as energy per unit volume in  $J/m^3$  (Black, 1988).

The above quantities can be measured using any of the displacement type sensors (e.g. strain gage, LVDT (Linear Variable Differential Transformer), capacitive, and piezoelectric sensors). The most commonly used sensors are the strain gage and the LVDT.

### Shear Loads

When forces are applied parallel to a surface or along the edge of an object, the object deforms in a way shown in Figure 9.12. The sides of the object perpendicular to the forces stretch and shear stresses and strains result.

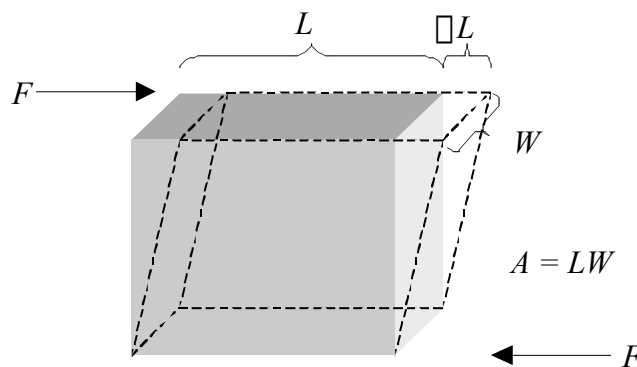

**Figure 9.12** Shear stress  $\Delta$  causes shear strain  $\Delta$

Shear strain,  $\Delta$  can be calculated using the formula

$$\Delta = \frac{\Delta L}{L} \quad (9.26)$$

Shear stress,  $\tau$  can be calculated using the formula

$$\tau = \frac{F}{A} \quad \Delta = F/A \quad (9.27)$$

where  $\Delta L$  is the distance of shear deformation,  $L$  is the original length,  $A$  is the cross-sectional area and  $F$  is the acting force.

The shear modulus,  $G$ , can be calculated using  $\Delta$  and  $\Delta L$  using the relationship:

$$G = \frac{\tau}{\Delta} \quad (9.28)$$

See more information about measuring shear stress and strain in Chapter 6.

### 9.12.3 Strain gage

The strain gage is a variable resistance sensor whose electric resistance is

$$R = \frac{\rho l}{A} \quad (9.29)$$

where  $R$  = resistance in  $\Omega$ ,  $\rho$  = resistivity in  $\Omega \cdot m$ ,  $l$  = length of the wire in m, and  $A$  = cross-sectional area in  $m^2$ . An increase in length causes an increase in resistance. The sensitivity is expressed by the gage factor

$$G = \frac{\Delta R/R}{\Delta L/L} = (1 + 2\nu) + \frac{\Delta \rho/\rho}{\Delta L/L} \quad (9.30)$$

where  $\nu$  is Poisson's ratio, which can be expressed as

$$\nu = -\frac{\Delta D/D}{\Delta L/L} \quad (9.31)$$

where  $D$  is the diameter of the cylindrical specimen. Poisson's ratio is the ratio between the lateral strain and axial strain. When a uniaxial tensile load stretches a structure, it increases the length and decreases the diameter.

Figure 9.13 shows four strain gage resistances that are connected to form a Wheatstone bridge. As long as the strain remains well below the elastic limit of the strain gage resistance, there is a wide range within which the increase in resistance is linearly proportional to the increase in length.

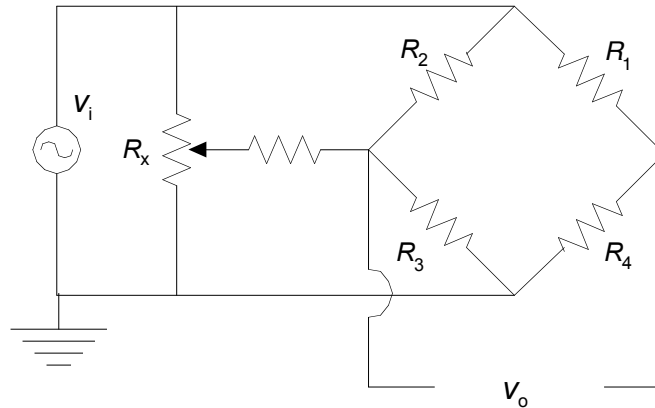
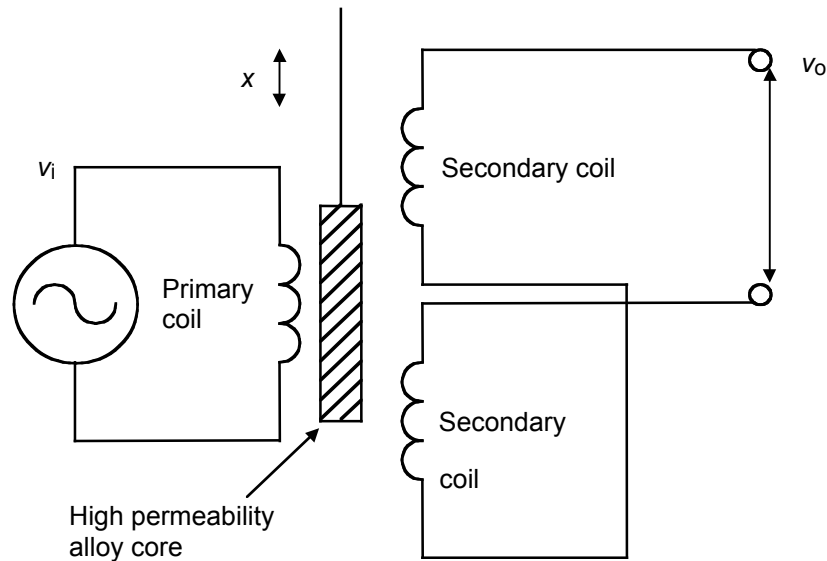

**Figure 9.13** Four strain gage resistances  $R_1$ ,  $R_2$ ,  $R_3$ , and  $R_4$  are connected as a Wheatstone bridge.  $v_i$  is the applied voltage with the bottom terminal grounded.  $v_o$  is the output voltage, which must remain ungrounded and feeds a differential amplifier. Potentiometer  $R_x$  balances the bridge. See section 2.1.6 for more information on Wheatstone bridges and potentiometers.

The types of strain gages are dictated by their construction. Unbonded strain gages may be formed from fine wires that are stretched when strained, but the resulting sensor is delicate. The wire's resistance changes because of changes in the diameter, length and resistivity. Bonded strain gages may be formed from wires with a plastic backing, which are glued onto a structural element, such as carefully dried bone. Integrated strain gages may be formed from impurities diffused into a silicon diaphragm, which forms a rugged pressure sensor (Peura and Webster, 1998). A strain gage on a metal spring is useful for measuring force within a uniaxial tensile test machine.

#### 9.12.4 LVDT

A transformer is a device used to transfer electric energy from one circuit to another. It usually consists of a pair of multiply wound, inductively coupled wire coils (inductors) that facilitate the transfer with a change in voltage, current or phase. A linear variable differential transformer (LVDT) is composed of a primary coil and two secondary coils connected in series opposition, as shown in Figure 9.14. The ac excitation is typically 5 V at 3 kHz. The coupling between these two coils is changed by the motion of the high permeability magnetic alloy between them. When the alloy is symmetrically placed, the two secondary voltages are equal and the output signal is zero. When the alloy moves up, a greater voltage is transformed to the top secondary coil and the output voltage is linearly proportional to the displacement. The LVDT is useful in determining the strain on tendons and ligaments (Woo and Young, 1991).



**Figure 9.14** In a linear variable differential transformer, displacement of the high permeability magnetic alloy changes the output voltage.

The most commonly used technique for measurement of stress and strain on bone specimens is the Uniaxial tension test using the LVDT. Figure 9.15 shows the set up for this test. It consists of one fixed and one moving head with attachments to grip the test specimen. A specimen is placed and firmly fixed in the equipment, a tensile force of known magnitude is applied through the moving head, and the corresponding elongation is measured. Then using Eqs. (9.24) and (9.25), the uniaxial stress and strain can be calculated.

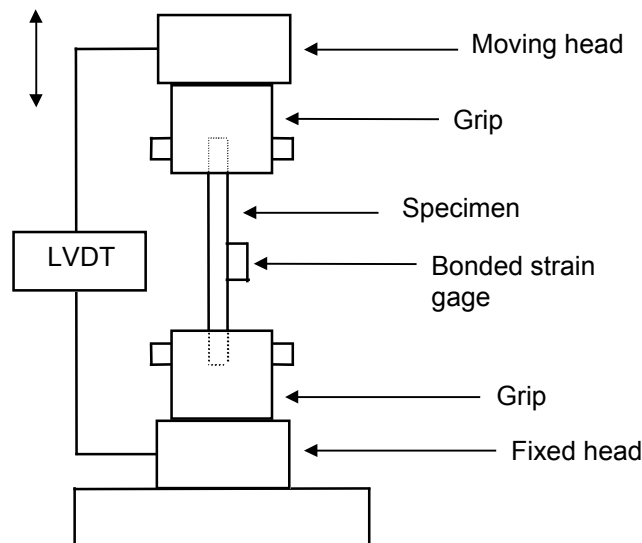

**Figure 9.15** The uniaxial tension test measures force versus elongation.

### 9.12.5 Soft tissue strain

A direct method of measuring ligament strain is by mounting a strain gage load cell within cadaveric knees (Markolf et al., 1990). A noncontact method for measuring ligament strain is the video dimension analyzer (VDA) (Woo et al., 1990). Reference lines are drawn on the specimen using stain and the test videotaped. The VDA system tracks the reference lines and yields strain versus time. Tendon and ligament tissues contain low-modulus elastin, which bears the majority of the load for strains up to about 0.07. At higher strains, collagen fibers, which possess a zigzag crimp, take an increasing portion of the load, resulting in an upward curvature of the stress–strain curve (Black, 1988).

Proteoglycans are important components of the extracellular matrix of articular cartilage and other soft tissues. Viscosity of proteoglycans extracted from cartilage can be measured using a cone-on-plate viscometer described in section 6.7.1 (Zhu and Mow, 1990). The angle of the cone  $\alpha$  is 0.04 and the diameter of the plate  $2a$  is 50 mm. The shear rate  $\dot{\gamma} = \omega/\alpha$ , where  $\omega$  is the rotational speed of the plate (rad/s). Apparent viscosity  $\mu_{app} = 3T/(2\alpha a^3\dot{\gamma})$ , where  $T$  = torque. Another viscometer is the Ostwald capillary viscometer, which calculates the coefficient of viscosity  $\mu$  from the pressure gradient  $dp/dL$ , the volume rate of flow  $Q$ , and the tube radius  $R$  using the equation  $\mu = [\pi R^4/(8Q)](dp/dL)$  (Fung, 1981). Another viscometer is the Couette coaxial viscometer in which an outer rotating cylinder transmits torque through the test fluid to an inner coaxial cylinder.

### 9.12.6 Joint friction

Diarthrodial (synovial) joints have a large motion between the opposing bones. To diagnose disease and to design artificial joints, we desire to measure friction between them. The resistance to motion between two bodies in contact is given by frictional force  $F = \mu W$ , where  $\mu$  is the coefficient of friction and  $W$  is the applied load (Black, 1988). Surface friction comes either from adhesion of one surface to another due to roughness on the two surfaces or from the viscosity of the sheared lubricant film between the two surfaces. Lubrication of bone joints is an important factor in determining coefficient of friction. Rheumatoid arthritis results in overproduction of synovial fluid in the joint and commonly causes swollen joints. The synovial fluid is the lubricating fluid that is used by the joints. The lubricating properties of the fluid depend on its viscosity; thin oil is less viscous and a better lubricant than thick oil. The viscosity of synovial fluid decreases under the large shear stresses found in the joint.

The coefficient of friction is measured in the laboratory using arthrotripsometers (pendulum devices). Here a normal hip joint from a fresh cadaver is mounted upside down with heavy weights pressing the head of femur into the socket. The weight on the joint is varied to study the effect of different loads. The whole unit acts like a pendulum with the joint serving as the pivot. From the rate of decrease of the amplitude with time, the coefficient of friction is calculated. It can be concluded that fat in the cartilage helps to reduce the coefficient of friction. When synovial fluid is removed, the coefficient of friction is increased considerably. Figure 9.16 shows an arrangement for measuring the coefficient of friction (Mow and Soslowky, 1991).



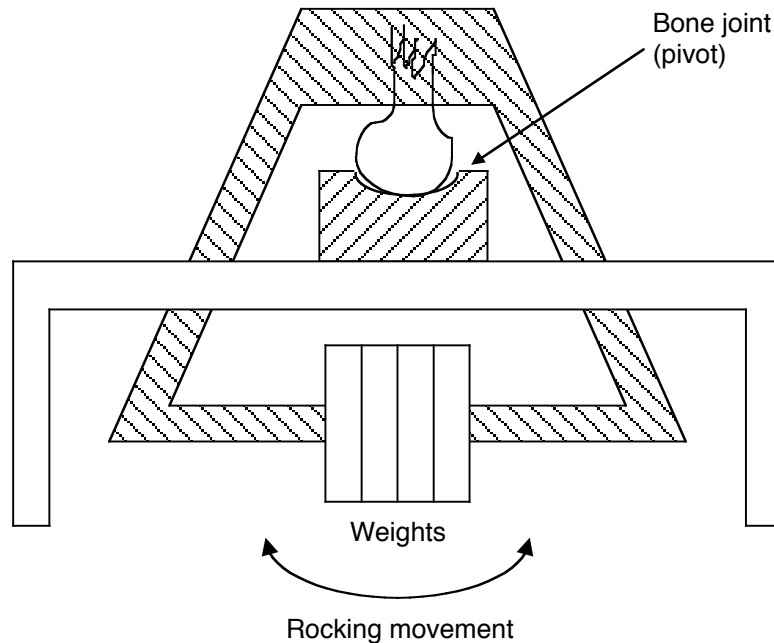

**Figure 9.16** Decay of oscillation amplitude in the pendulum device permits calculation of the coefficient of friction of a joint.

We wish to measure wear in joints of artificial materials such as ultra-high-molecular-weight polyethylene (UHMWPE) (Dowson, 1990). For polymeric materials, the volume  $V = kPX$  produced by wear during sliding against metallic or ceramic countersurfaces is proportional to the applied load  $P$  and the total sliding distance  $X$ .  $k$  is a wear factor indicative of the wear resistance of a material.

### 9.12.7 Bone position

Bone position is important for calculating the loading forces that act on it. The most complicated bones in the body on which these forces are calculated are in the spinal cord. Calculating forces for other bones, such as the femur, is relatively easy. These loading forces are static and dynamic in nature.

A goniometer is an electric potentiometer that can be attached to a joint to measure its angle of rotation. For working details of the goniometer refer to Chapter 10.

Human joint and gross body motions can be measured by simple protractor type goniometers, electrogoniometers, exoskeletal linkage devices, interrupted light or normal and high speed photography, television-computer, X-ray or cineradiographic techniques, sonic digitizers, photo-optical technique, and accelerometers (Engin, 1990).

### 9.12.8 Bone strain-related potentials

Bending a slab of cortical or whole living or dead bone yields piezoelectric potentials of about 10 mV, which we can measure using electrodes (Black, 1988). If the strain is maintained, the

potentials rapidly decay to a very low value, called the offset potential. Some workers hypothesize that these potentials have a role in directing growth, healing, and remodeling.